

HAND HELD DOPPLER

The Series UFX Doppler Flow Meter features an advanced ultrasonic measuring technology, providing accurate and reliable flow velocity assessments in closed piping systems. The UFX utilizes a non-invasive, hand held transducer which is placed on the outside of the pipe. Within seconds, the large 0.7 inch (18 mm) LCD provides stable readings in feet per second or meters per second. This product operates on metal or plastic pipes containing liquids with greater than 100 ppm of 100 micron size suspended solids or entrained gases.

The Series UFX flow meter is a cost-effective flow measurement system for closed full pipes size ¼" (6 mm) and above. The easy to use hand held transducer provides accurate flow readings on applications such as dredging systems, crude oil, sludges, and waste slurries.

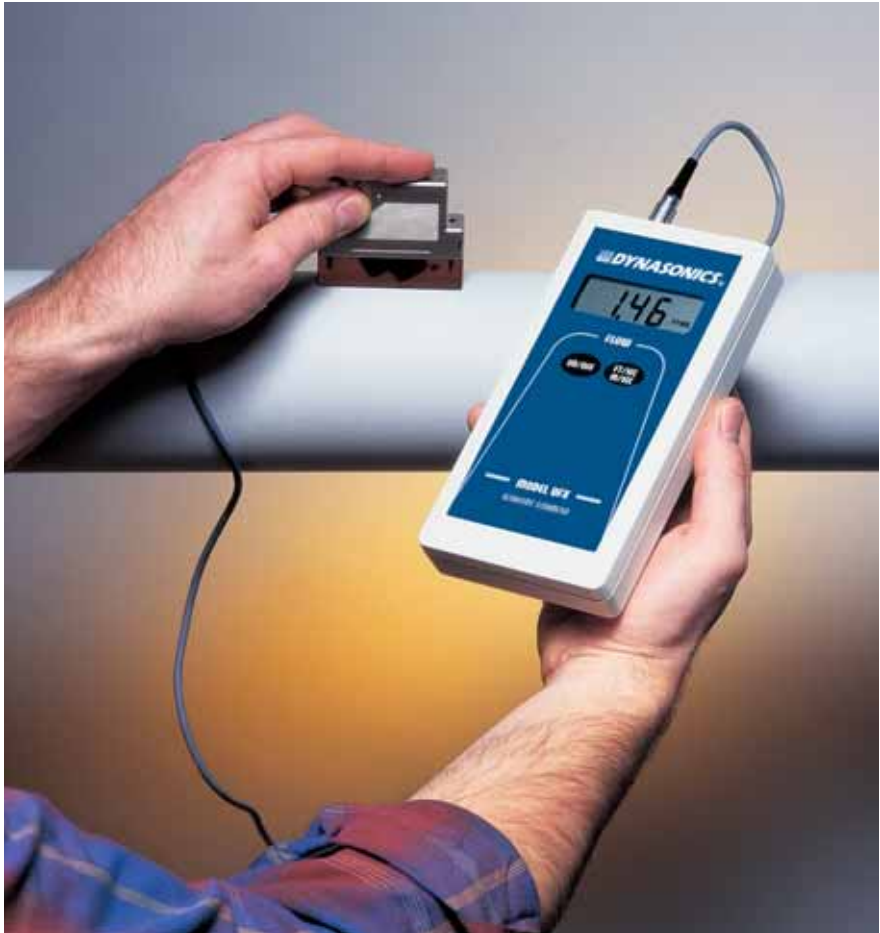

FEATURES

- Utilizes a non-invasive, hand held transducer and Type 3 (IP 64) battery operated enclosure.
- Measures fluid velocities from 0.3 to 30 FPS (0.1 to 9 MPS).
- Reliable readings on nearly all liquid applications containing a minimum of 100 ppm of 100 micron size suspended solids or entrained gases.
- Optional CE Approval transducer for pipes size ¼" and above.
- Low cost unit with accurate readings on closed full pipes size ¼" (6 mm) and above.
- Large four-digit LCD display provides velocity readout in user selected units (FPS or MPS).
- Easy to use flow verification instrument for industrial and municipal applications; including paper pulp stock, concrete slurries, dredging applications, primary sludge and waste activated sludge.

OPERATING PRINCIPLE

The Series UFX flow meter utilizes an advanced ultrasonic measuring technique, providing accurate, non-invasive, fluid velocity assessment without opening the pipe. The UFX utilizes two piezoelectric crystals contained within one transducer to transmit ultrasonic energy into the fluid stream and receive reflected energy off discontinuities (suspended particles or entrained gases) within the moving liquid. Transformations that result from the energy reflections are processed and converted to fluid velocity by the UFX's sophisticated software algorithm. The processor also controls all operations of the instrument from its ultra efficient battery management circuitry to a proprietary FIR (Finite Impulse Response) filtration program.

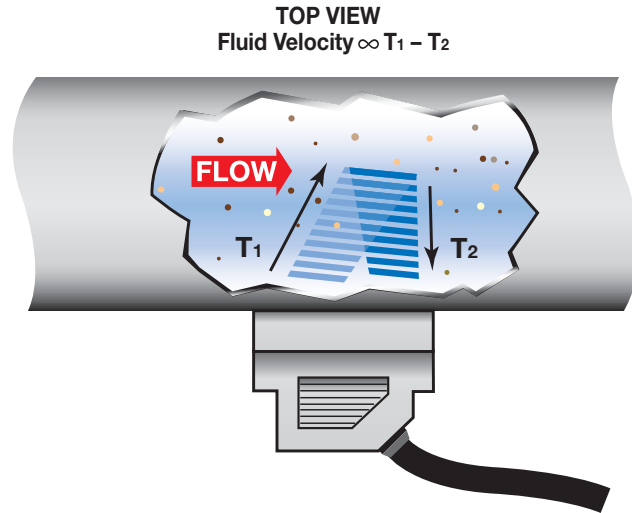

DIMENSIONAL SPECIFICATIONS

MECHANICAL DIMENSIONS: INCHES (mm)

CABLE LENGTH
6.6 feet (2 Meters)

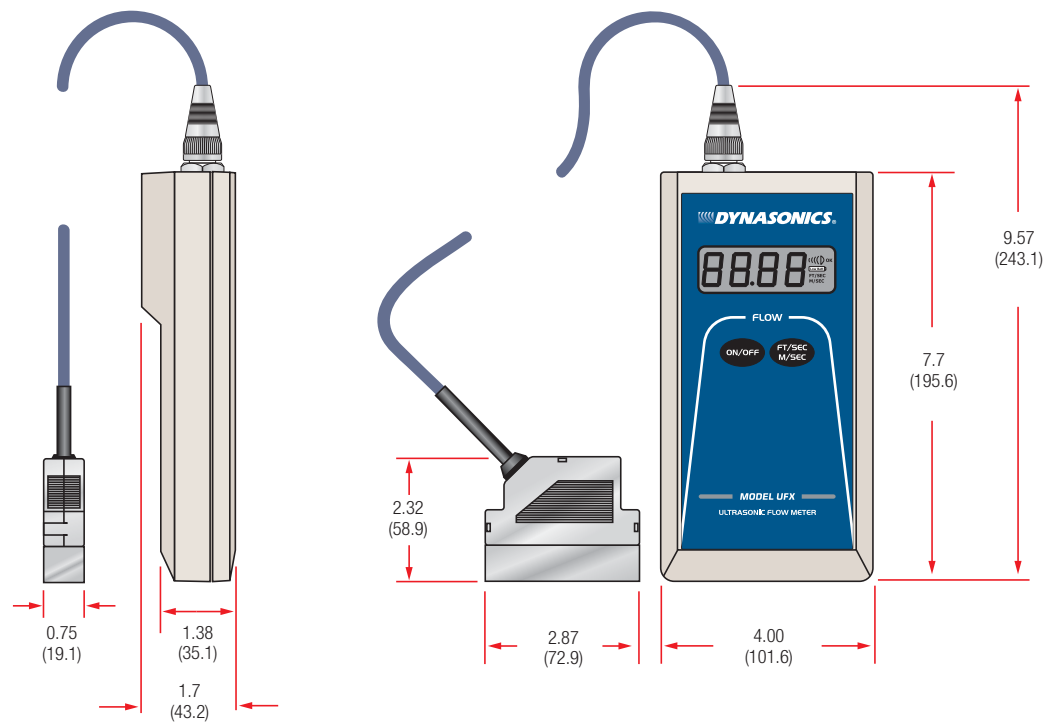

Optional Small Pipe
Transducer & Cable
Assembly

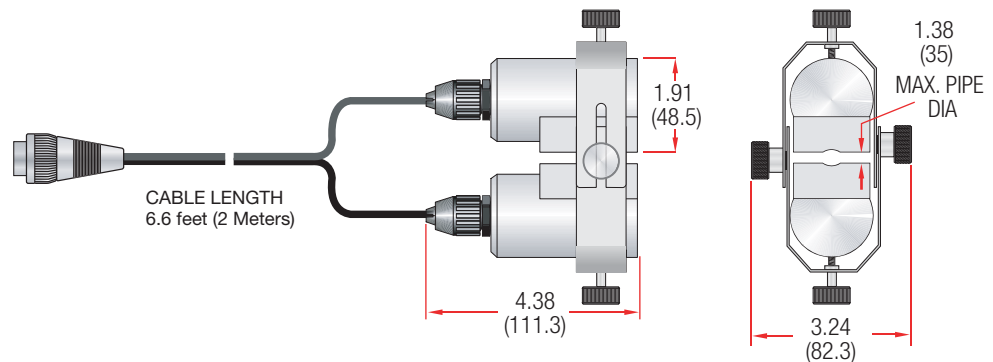

SPECIFICATIONS

DESCRIPTION	SPECIFICATION
Liquid Requirements	100 PPM of 100 micron size suspended solids or entrained gases
Pipe Sizes	(Std) 1 inch (25 mm) and above (Small pipe) ¼ to 1 inch (6 to 25 mm)
Flow Range	0.3 to 30 FPS (0.1 to 9 MPS)
Accuracy	±2% of full scale
Display	Single line – four digit LCD readout of velocity (0.7 inches (18 mm) high digits), signal strength, measuring units, and low battery indication
Enclosure Rating Dimensions	Type 3 (IP 64) ABS plastic; 1.5 lbs. (0.7 kg) 7.7 inches H x 4 inches W x 1.7 inches D (195.6 mm x 101.6 mm x 43.2 mm)
Transducer Material	Plated body; ULTEM® 1000 sensor material
Ambient Temperature	-28 °F to +140 °F (-20 °C to +60 °C)
Liquid Temperature	-40 °F to +180 °F (-40 °C to +82 °C)
Humidity	0 to 95% non-condensing
Supply Voltage	Battery powered; non-rechargeable alkaline, four AA cells; providing over 30 hours of continuous operation
Cable	6.6 feet (2 m) cable and connector
Mounting Method	Clamp-on style with Dow 111 coupling compound
Certifications:	CE

PART NUMBER CONSTRUCTION

DUFX1 - -

Transducer Type

- B1)** Small Pipe, ¼" to 1" (6 to 25 mm)
- D1)** Std. Pipe, 1" (25 mm) and above
- F1)** Both B1 and D1

Approvals

- CE)** CE Generic Light Industrial
(Leave blank if no approvals are required)

Note: Includes carrying case, one tube silicone couplant (for temporary mounting), and four AA batteries

SPARE PARTS AND ACCESSORIES

Description	Part Number
Nylon Mounting Strap 30 inch (750 mm)	D002-2007-002
Couplant, Silicone (for temporary mounting)	D002-2011-001
SS Identification Tag	D003-0825-001
Series DUFX Standard Pipe Transducer	DTUFX-D1
Series DUFX Standard Pipe Transducer with CE Approval	DTUFX-D1-CE
Series DUFX Small Pipe Transducer	DTUFX-B1
Series DUFX Standard Pipe Transducer with CE Approval	DTUFX-B1-CE
UFX Carrying Case	D003-1009-005

Velocity to Volumetric Flow Calculator included

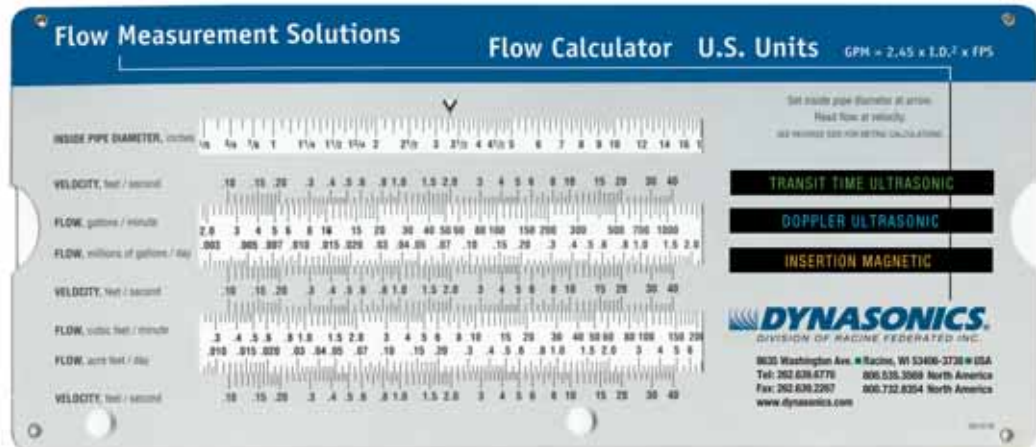

Technology Selection Guide

Liquid Type (in order of increasing % of suspended solids)

Ultrapure Liquids
Deionized Water
Water Filter-Bed Effluent

Hydraulic Oil

Refined Hydrocarbons
Beverages
Well Water

Reclaimed Water

Cooling Tower
Ground Water

Raw Sewage
Gray Water

Beverages - Carbonated

Waste Activated Sludge
Return Activated Sludge

Mining Slurries

Filter Backwash

Paper Pulp Stock

Dredging Applications

Preprocessed Crude Oil

Primary Sludge
Lime Sludge
Digested Sludge

Concrete



Transit Time



Enhanced Doppler



Doppler

This guide provides general rules for the selection of an appropriate Dynasonics ultrasonic technology – it is neither exhaustive nor absolute. System factors such as temperature, pipe materials, suspended solid composition and liquid velocity can influence product selection. It is best to present application information to a Dynasonics Sales Representative or to the Dynasonics factory for evaluation.

Dynasonics offers the most comprehensive line of ultrasonic transit time and Doppler flow meters in the world. These meters are clamp-on, non-invasive flow meters that require a good acoustical path between the outside of the pipe and the liquid inside. In some instances, such as non-saturated concrete pressure pipe, ultrasonic energy will not readily pass. For these installations, Dynasonics offers the Series MFX MagProbe™ as well as an insertion Doppler probe.

Please consult a Dynasonics Sales Representative or the Dynasonics factory to discuss the use of these products in your flow measurement application.



DYNASONICS
DIVISION OF RACINE FEDERATED INC.

8635 Washington Ave ■ Racine, WI 53406 ■ USA
Tel: 262.639.6770 800.535.3569 US & Canada
Fax: 262.639.2267 800.732.8354 US & Canada
www.dynasonics.com

DYNASONICS is a registered trademark of Racine Federated Inc.
MagProbe is a trademark of Racine Federated Inc.
ULTEM is a registered trademark of General Electric Co.
©2009 Racine Federated Inc., all rights reserved.

FORM UFX 5/09